

PENTA-D 70/280

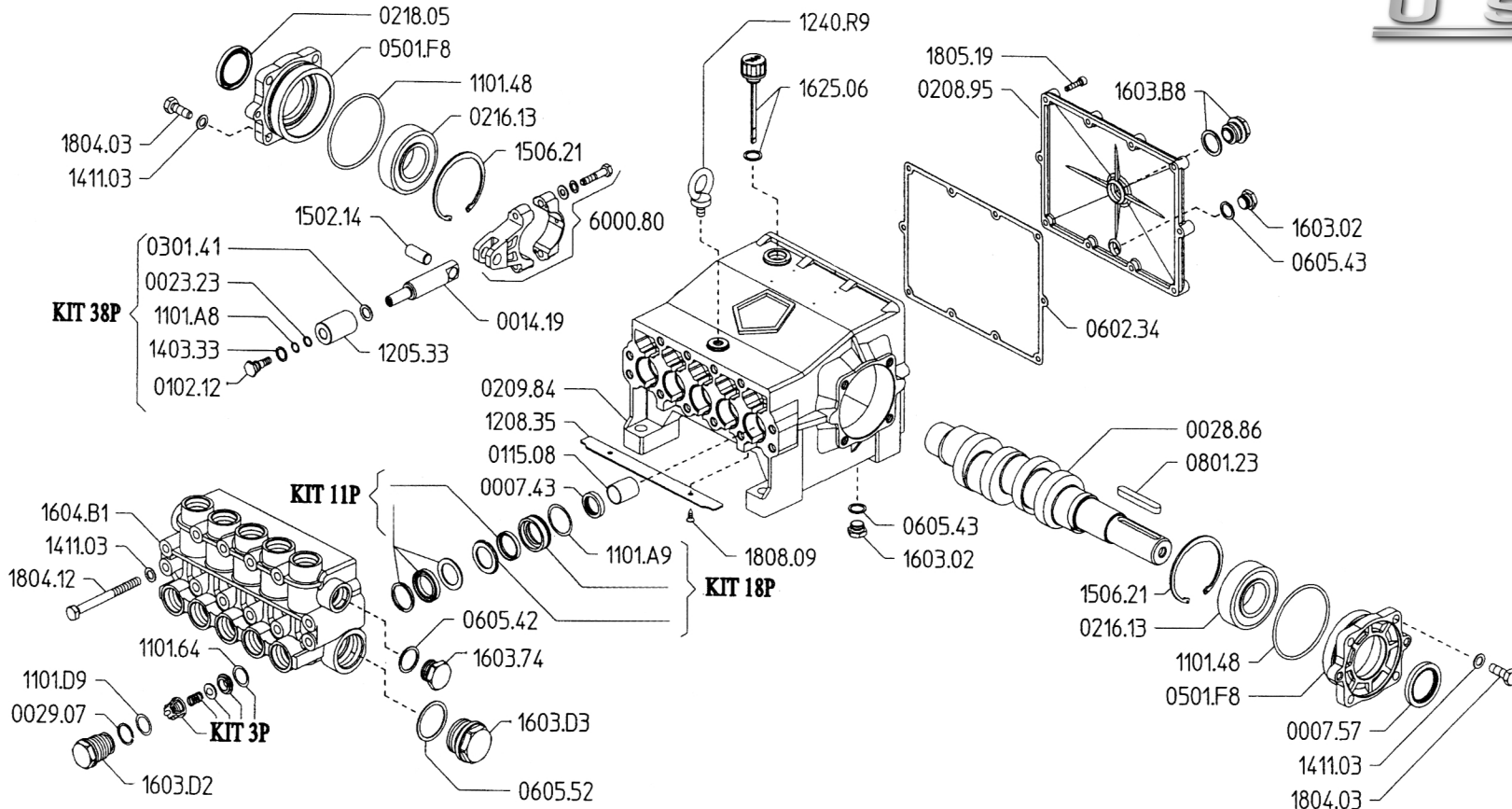

Your Authorized Dealer is:

Municipal Equipment Sales, Inc.

Mailing Address: PO Box 1233
 Location: 208 Bell Place
 Woodstock, GA 30188



Local: 770-928-0424
 Fax: 770-928-7512
 Nationwide Toll Free: **1-800-782-2243**
 Email: sales@municipalequipment.com
 Web: www.municipalequipment.com



PENTA-D 70/280 Quick Reference

Maximum Flow	18 GPM	Valve Kit.....	04-KIT UD-3P
Maximum Pressure	4000 PSI	Seal Kit	04-KIT UD-11P
Rated Pump Speed	1750 RPM	Brass Kit.....	04-KIT UD-18P
Oil Capacity.....	80 oz. UDOR LUBE	Plunger Bolt Kit.....	04-KIT UD-38P
	or SAE 30W	Plunger Part #	04-1205.33
	Non-Detergent Oil	Plunger Diameter.....	25 MM