

TranSTAR Transporter

Changing the Way You Inspect Pipelines

RS Technical Services adds to the family of mainline tractor transport vehicles with the TranSTAR. Innovative technology utilizes easy access on the transporter chassis to swap out the motor drive gear set when a change in motor torque is needed.

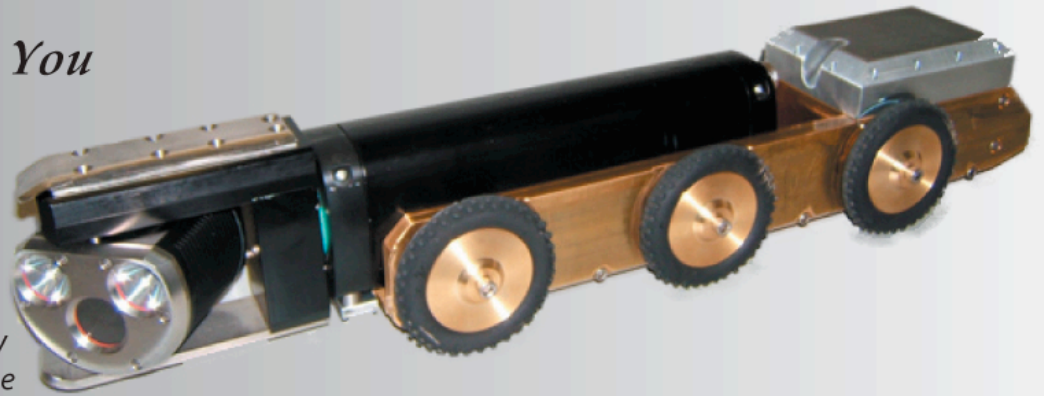

Note: See your distributor for other camera options.

Features

- **Quick Change Gears**
Accessible motor drive gear on transporter chassis. Install gear sets of alternate ratios to optimize the transporter for the existing or potentially changing load conditions.
- **All Wheel Drive**
Gear driven wheels employing ball-bearing supported steel precision machined gears encased in brass. Sealed hubs prevent moisture or dirt from entering gear case.
- **Freewheel Clutch**
Allows rapid retrieval once inspection is complete.
- **Rare-Earth Permanent Magnet Motor**
Rated at 1/8 HP (90 watts, continuous) to provide a smooth, powerful drive source.
- **Single Conductor Coax Control**
Speed control and DC power from single conductor coax TV cable.
- **Torque Multiplier Circuit**
Internal control when that extra boost is needed.
- **Precision Machined Construction**
CNC precision machined brass 360 plate gear housing shafts and stainless steel hubs.
- **Large Size Tires Available**
- **Optional Extension Sets**

Specifications

- **Environmental Operating Conditions**
Water resistant per IPX7
Temperature: -10° to +40°C
- **Power Requirements**
Operates on all standard RST single conductor systems. Optional multi-conductor is available.
- **Maximum Input**
180 watts (peak), 1.5 amps
- **Maximum Pipe Size**
(Adjustable with optional axle and wheel combinations)
- **Speed Range**
5 to 70 feet per minute (fpm)
- **Dimensions**
Overall Length: 18.9"
Wheel Base: 11.0"
Width: 4.2"
Height: 4.2"
Base Weight: 25.0 lbs
(Without OMNI EYE III Camera)

TranSTAR Transporter

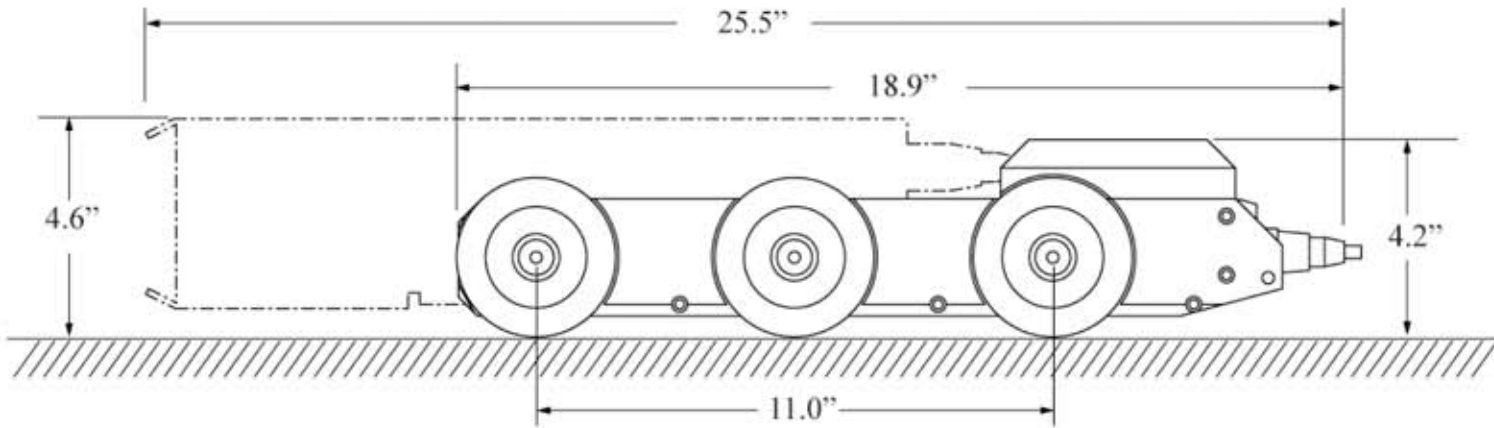

Side View Dimensions*

* Dimensions shown with and without OMNI EYE III Camera

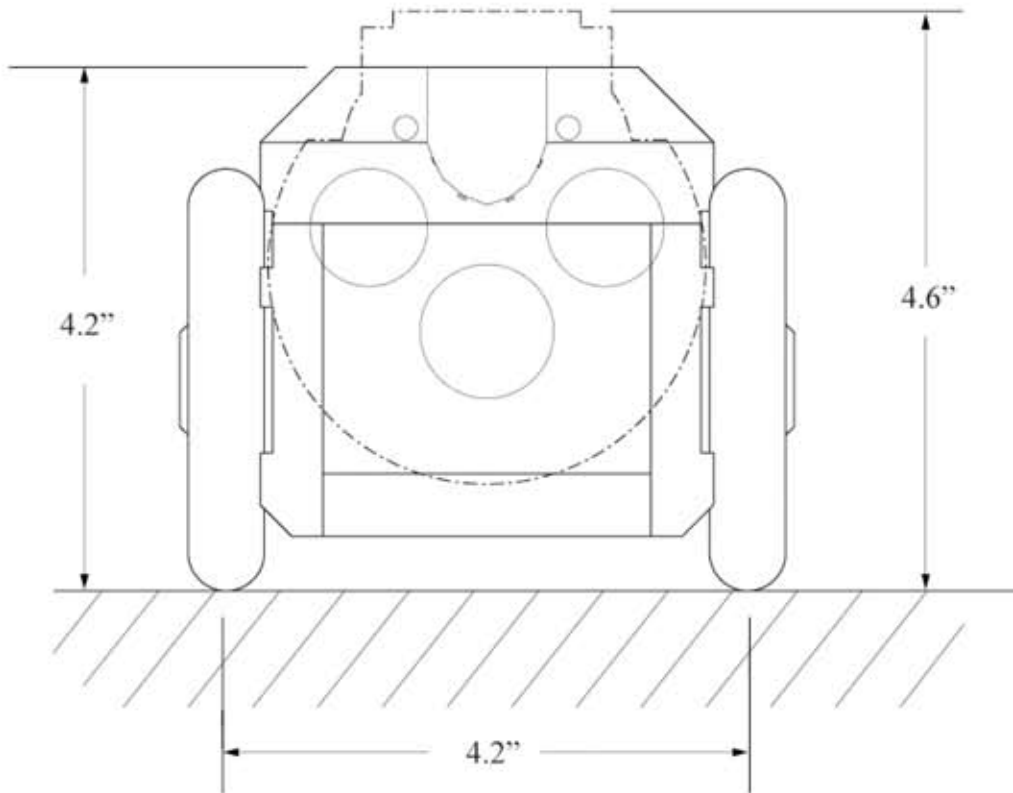

Front View (with OMNI EYE III Camera)

Your Authorized Dealer is:

Municipal Equipment Sales, Inc.

Mailing Address: PO Box 1233
Location: 208 Bell Place
Woodstock, GA 30188

Local: 770-928-0424
Fax: 770-928-7512
Nationwide Toll Free: 1-800-782-2243
Email: sales@municipalequipment.com
Web: www.municipalequipment.com

